

cobra

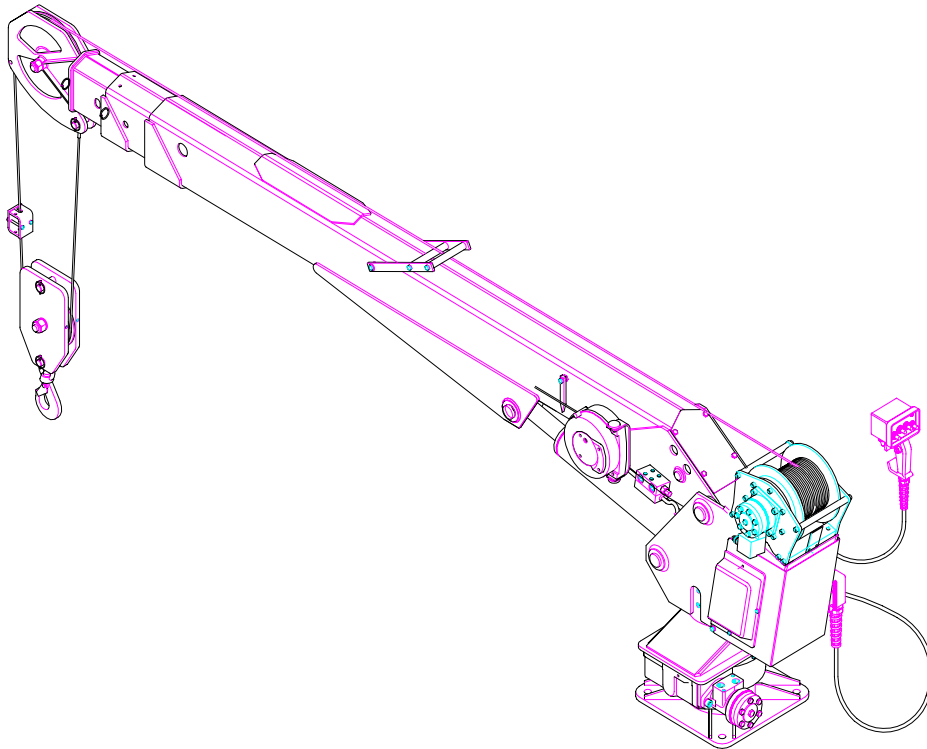

Cranes meet:

- Standard **ANSI B30.5**
OSHA 1910-180 requirements
- Standard **DIN 15018**
Lifting class **H2-B3**



Next Hydraulics[®] s.r.l.

Via Mediterraneo, 6 • 42022 Boretto (R.E.) • ITALY
☎ +39 0522 963008 • FAX +39 0522 963039
E-mail: info@maxiliftcrane.com
Web: www.maxiliftcrane.com



**3300 W****Rating 11,500 ft. lbs. (KNm. 16)**§ - Crane structure designed according **DIN 15018** Standards - Lifting class **H2-B3**§ - Complies with **ANSI B30.5** (1989, rev. 1992) **OSHA** 1910-180, dtd 7-1-91**Standard features :**

- telescopic boom system, one stage hydraulic and one manual
- protected extension cylinder placed inside the boom
- hydraulic slewing system by worm gear, full 400° rotation
- sheaves made in low friction, high strength, weather-proof polymer
- travelling block, swivel hook with safety latch
- full safety control system, integrating load limiting device, anti-two block and stop-end rope system on drum
- electrical winch placed on proper bracket on the column, the pendant control box enables simultaneous operation of winch plus any other crane function.
- 82 ft. (25 mt.) of 1/4 " (6 mm.) rope 6,000 lbs. 2,650 kg.) minimum breaking strength, non twisting type.
- ON/OFF remote control with one handheld ergonomic and light control box with 26 ft. (8 mt.) cable
- possible interface with any commercial radio system
- digital processor control unit in waterproof case with quick connection, waterproof connectors placed in protected position under casing.
- column mounted, heavy duty DC power-pack, 12V-1.5 kW.
- solenoid operated valves with emergency manual override
- painted COBRA WHITE (RAL 9003), fading resistant polyurethane enamel

ELECTRO-HYDRAULIC CRANE

3300 W	<i>COBRA model</i>	<i>Description</i>	<i>Part #</i>	<i>List price : US\$</i>
	◦ COBRA 3300 W	- complete with winch, rope with hook (electric system 12V)	13.0.832	11.773

ACCESSORIES	<i>Description</i>	<i>Part #</i>	<i>List price : US\$</i>
	◦ Extra-price for electric cable reel	13.5.521	208
	◦ Extra-price for radio ON/OFF remote control (4 functions)	RC.0.009	1.983
	◦ Hook ring for travelling block	13.2.515	61
	◦ Outriggers :		
	One side manual out, both legs manual up/down 2.3 F-EMO M	13.4.501	1.192
	One side manual out, both legs hydraulic up/down 2.3 F-EMO K	13.4.502	2.275

Net price for crane packaging (conform ISPM 15 + HT) :

US\$ **190**

§ - Crane structure designed according **DIN 15018** Standards - Lifting class **H2-B3**

§ - Complies with **ANSI B30.5** (1989, rev. 1992) **OSHA** 1910-180, dtd 7-1-91

Standard features :

- ° telescopic boom system, one stage hydraulic and one manual
- ° protected extension cylinder placed inside the boom
- ° hydraulic planetary winch, high speed and efficiency
- ° hydraulic slewing system, full 400° rotator
- ° sheaves made in low friction, high strength, weather-proof polymer
- ° 82 ft. (25 mt.) of 1/4 " (6 mm.) rope 6,000 lbs. (2,650 kg.) minimum breaking strength, non twisting type
- ° travelling block, swivel hook with safety latch
- ° full safety control system, integrating load limiting device, anti-two block and stop-end rope system on drum
- ° fully digital proportional controls, enable fast, precise, smooth operation. Easy upgrading from wire to radio with minimal changes
- ° digital processor, LED display, on IP 67 water proof casing, providing self-diagnostic and quick settings
- ° one handheld trigger type control box for wire or radio remote, incorporating emergency shut-off and start/stop truck engine switch
- ° solenoid operated valves with emergency manual override
- ° painted COBRA WHITE (RAL 9003), fading resistant polyurethane enamel

Only on the electro-hydraulic crane :

- ° column mounted, heavy duty DC power-pack, 12V-1.5 kW or 24V- 2.0 kW

With radio remote :

(PTO driven and electro-hydraulic)

- ° magnet for control box leaning
- ° battery recharging cable 6 ft. (2 mt.) length with plug for in-cab cigarette lighte

HYDRAULIC CRANE

3300....H	<i>COBRA model</i>	<i>Description</i>	<i>Part #</i>	<i>List price : US\$</i>
	3300 KP-H 12V	<i>including mono-function proportional micro-processor system for cable remote control - DBX enclosure (12V system)</i>	13.0.861	12.635
	3300 KP-H 24V	<i>remote control - DBX enclosure (24V system)</i>	13.0.863	12.635
	3300 KPD-H 12V	<i>including dual-function proportional micro-processor system for cable remote control - DBX enclosure (12V system)</i>	13.0.865	13.739
	3300 KPD-H 24V	<i>remote control - DBX enclosure (24V system)</i>	13.0.867	13.739
	3300 RKP-H 12V	<i>including mono-function proportional micro-processor system for radio remote control - DBX enclosure (12V system)</i>	13.0.871	14.341
	3300 RKP-H 24V	<i>remote control - DBX enclosure (24V system)</i>	13.0.873	14.341
	3300 RKPD-H 12V	<i>including dual-function proportional micro-processor system for radio remote control - DBX enclosure (12V system)</i>	13.0.875	15.445
	3300 RKPD-H 24V	<i>remote control - DBX enclosure (24V system)</i>	13.0.877	15.445

ELECTRO-HYDRAULIC CRANE

3300....E	<i>COBRA model</i>	<i>Description</i>	<i>Part #</i>	<i>List price : US\$</i>
	3300 KP-E 12V	<i>including mono-function proportional micro-processor system for cable remote control - DBX enclosure (12V system)</i>	13.0.862	14.169
	3300 KP-E 24V	<i>remote control - DBX enclosure (24V system)</i>	13.0.864	14.169
	3300 RKP-E 12V	<i>including mono-function proportional micro-processor system for radio remote control - DBX enclosure (12V system)</i>	13.0.872	15.877
	3300 RKP-E 24V	<i>remote control - DBX enclosure (24V system)</i>	13.0.874	15.877

ACCESSORIES

	<i>Description</i>	<i>Part #</i>	<i>List price : US\$</i>
	° 4 gallons (15 lt.) reservoir oil, with filter on return line (only PTO driven,	06.5.501	147
	° Kit radio remote for compressor and accelerator (7 functions in the pendant	10.5.532	1.235
	° Extra-price for electric cable reel	13.5.521	208
	° Remote control wire 30 ft. where or when radio operation is not permitted	CV.0.071	263
	° Hook ring for travelling block	13.2.515	61
	One side manual out, both legs manual up/down 2.3 F-EMO M	13.4.501	1.192
	One side manual out, both legs hydraulic up/down 2.3 F-EMO K	13.4.502	2.275

Net price for crane packaging (conform ISPM 15 + HT) :

US\$ **190**

**4400 W****Rating 16,000 ft. lbs. (KNm. 22)**§ - Crane structure designed according **DIN 15018** Standards - Lifting class **H2-B3**§ - Complies with **ANSI B30.5** (1989, rev. 1992) **OSHA** 1910-180, dtd 7-1-91**Standard features :**

- telescopic boom system, one stage hydraulic and one manual
- protected extension cylinder placed inside the boom
- hydraulic slewing system by worm gear, full 400° rotation
- sheaves made in low friction, high strength, weather-proof polymer
- travelling block, swivel hook with safety latch
- full safety control system, integrating load limiting device, anti-two block and stop-end rope system on drum
- electrical winch placed on proper bracket on the column, the pendant control box enables simultaneous operation of winch plus any other crane function.
- 100 ft. (30 mt.) of 5/16" (8 mm.) rope 13,300 lbs. (6,050 kg.) minimum breaking strength, non twisting type.
- ON/OFF remote control with one handheld ergonomic and light control box with 26 ft. (8 mt.) cable
- possible interface with any commercial radio system
- digital processor control unit in waterproof case with quick connection, waterproof connectors placed in protected position under casing.
- column mounted, heavy duty DC power-pack, 12V-1.5 kW.
- solenoid operated valves with emergency manual override
- painted COBRA WHITE (RAL 9003), fading resistant polyurethane enamel

ELECTRO-HYDRAULIC CRANE

4400 W	<i>COBRA model</i>	<i>Description</i>	<i>Part #</i>	<i>List price : US\$</i>
	◦ COBRA 4400 W	- complete with winch, rope with hook (electric system 12V)	13.0.849	13.973

ACCESSORIES	<i>Description</i>	<i>Part #</i>	<i>List price : US\$</i>
	◦ Extra-price for radio ON/OFF remote control (4 functions)	RC.0.009	1.983
	◦ Hook ring for travelling block	13.2.515	61
	One side manual out, both legs hydraulic up/down 2.3 F-EMO M	13.4.501	1.192
	One side manual out, both legs hydraulic up/down 2.3 F-EMO K	13.4.502	2.275
	One side manual out, both legs manual up/down 4.5 F-EMO M	10.4.525	1.867

Net price for crane packaging (conform ISPM 15 + HT) : **US\$ 190**



4400....

Rating 16,000 ft. lbs. (KNm. 22)

§ - Crane structure designed according **DIN 15018 Standards - Lifting class H2-B3**

§ - Complies with **ANSI B30.5** (1989, rev. 1992) **OSHA** 1910-180, dtd 7-1-91

Standard features :

- ° telescopic boom system, one stage hydraulic and one manual
- ° protected extension cylinder placed inside the boom
- ° hydraulic planetary winch, high speed and efficiency
- ° hydraulic slewing system, full 400° rotation
- ° sheaves made in low friction, high strength, weather-proof polyme
- ° 100 ft. (30 mt.) of 5/16 " (8 mm.) rope 13,300 lbs. (6,050 kg.) minimum breaking strength, non twisting type
- ° travelling block, swivel hook with safety latch
- ° full safety control system, integrating load limiting device, anti-two block and stop-end rope system on drur
- ° fully digital proportional controls, enable fast, precise, smooth operation. Easy upgrading from wire to radio with minimal change:
- ° digital processor, LED display, on IP 67 water proof casing, providing self-diagnostic and quick settings
- ° one handheld trigger type control box for wire or radio remote, incorporating emergency shut-off and start/stop truck engine switch
- ° solenoid operated valves with emergency manual override
- ° painted COBRA WHITE (RAL 9003), fading resistant polyurethane enamel

Only on the electro-hydraulic crane :

- ° column mounted, heavy duty DC power-pack, 12V-1.5 kW or 24V- 2.0 kW

With radio remote :

(PTO driven and electro-hydraulic)

- ° magnet for control box leaning
- ° battery recharging cable 6 ft. (2 mt.) length with plug for in-cab cigarette lighte

HYDRAULIC CRANE

4400....H	<i>COBRA model</i>	<i>Description</i>	<i>Part #</i>	<i>List price : US\$</i>
4400 KP-H 12V		<i>including mono-function proportional (12V system)</i>	13.0.881	13.311
4400 KP-H 24V		<i>micro-processor system for cable remote control - DBX enclosure (24V system)</i>	13.0.883	13.311
4400 KPD-H 12V		<i>including dual-function proportional (12V system)</i>	13.0.885	14.415
4400 KPD-H 24V		<i>micro-processor system for cable remote control - DBX enclosure (24V system)</i>	13.0.887	14.415
4400 RKP-H 12V		<i>including mono-function proportional (12V system)</i>	13.0.891	15.017
4400 RKP-H 24V		<i>micro-processor system for radio remote control - DBX enclosure (24V system)</i>	13.0.893	15.017
4400 RKP-H 12V		<i>including dual-function proportional (12V system)</i>	13.0.895	16.121
4400 RKP-H 24V		<i>micro-processor system for radio remote control - DBX enclosure (24V system)</i>	13.0.897	16.121

ELECTRO-HYDRAULIC CRANE

4400....E	<i>COBRA model</i>	<i>Description</i>	<i>Part #</i>	<i>List price : US\$</i>
4400 KP-E 12V		<i>including mono-function proportional (12V system)</i>	13.0.882	14.777
4400 KP-E 24V		<i>micro-processor system for cable remote control - DBX enclosure (24V system)</i>	13.0.884	14.777
4400 RKP-E 12V		<i>including mono-function proportional (12V system)</i>	13.0.892	16.485
4400 RKP-E 24V		<i>micro-processor system for radio remote control - DBX enclosure (24V system)</i>	13.0.894	16.485

ACCESSORIES

	<i>Description</i>	<i>Part #</i>	<i>List price : US\$</i>
°	4 gallons (15 lt.) reservoir oil, with filter on return line (only PTO driven)	06.5.501	147
°	Hook ring for travelling block	13.2.515	61
°	Kit radio remote for compressor and accelerator (7 functions in the pendant)	10.5.532	1.235
°	Remote control wire 30 ft. where or when radio operation is not permitted	CV.0.071	263
°	Outriggers :		
	One side manual out, both legs manual up/down 2.3 F-EMO M	13.4.501	1.192
	One side manual out, both legs hydraulic up/down 2.3 F-EMO K	13.4.502	2.267
	One side manual out, both legs manual up/down 4.5 F-EMO M	10.4.525	1.867

Net price for crane packaging (conform ISPM 15 + HT) :

US\$ **190**



5105....

Rating 25,000 ft. lbs. (KNm. 35)

§ - Crane structure designed according **DIN 15018 Standards - Lifting class H2-B3**

§ - Complies with **ANSI B30.5** (1989, rev. 1992) **OSHA** 1910-180, dtd 7-1-91

Standard features :

- ° telescopic boom system, two fully hydraulic stages
- ° protected extension cylinders placed inside the boom
- ° hydraulic planetary winch, high speed and efficiency
- ° hydraulic slewing system, unlimited, continuous rotation
- ° sheaves made in low friction, high strength, weather-proof polyme
- ° 100 ft. (30 mt.) of 5/16 " (8 mm.) rope 13,300 lbs. (6,050 kg.) minimum breaking strength, non twisting type
- ° travelling block, swivel hook with safety latch
- ° full safety control system, integrating load limiting device, anti-two block and stop-end rope system on drur
- ° fully digital proportional controls, enable fast, precise, smooth operation. Easy upgrading from wire to radio with minimal change:
- ° digital processor, LED display, on IP 67 water proof casing, providing self-diagnostic and quick settings
- ° one handheld trigger type control box for wire or radio remote, incorporating emergency shut-off and start/stop truck engine switch
- ° solenoid operated valves with emergency manual override
- ° painted COBRA WHITE (RAL 9003), fading resistant polyurethane enamel

Only on the electro-hydraulic crane :

- ° column mounted, heavy duty DC power-pack, 12V-2.5 kW or 24V- 3.0 kW

With radio remote :

(PTO driven and electro-hydraulic)

- ° magnet for control box leaning
- ° battery recharging cable 6 ft. (2 mt.) length with plug for in-cab cigarette lighte

HYDRAULIC CRANE

5105....H	COBRA model	Description	Part #	List price : US\$
	5105 KP-H 12V	including mono-function proportional micro-processor system for cable remote control - DBX enclosure (12V system)	10.0.851	16.887
	5105 KP-H 24V	remote control - DBX enclosure (24V system)	10.0.853	16.887
	5105 KPD-H 12V	including dual-function proportional micro-processor system for cable remote control - DBX enclosure (12V system)	10.0.855	17.768
	5105 KPD-H 24V	remote control - DBX enclosure (24V system)	10.0.857	17.768
	5105 RKP-H 12V	including mono-function proportional micro-processor system for radio remote control - DBX enclosure (12V system)	10.0.861	18.412
	5105 RKP-H 24V	remote control - DBX enclosure (24V system)	10.0.863	18.412
	5105 RKP-H 12V	including dual-function proportional micro-processor system for radio remote control - DBX enclosure (12V system)	10.0.865	19.295
	5105 RKP-H 24V	remote control - DBX enclosure (24V system)	10.0.867	19.295

ELECTRO-HYDRAULIC CRANE

5105....E	COBRA model	Description	Part #	List price : US\$
	5105 KP-E 12V	including mono-function proportional micro-processor system for cable remote control - DBX enclosure (12V system)	10.0.852	18.452
	5105 KP-E 24V	remote control - DBX enclosure (24V system)	10.0.854	18.452
	5105 RKP-E 12V	including mono-function proportional micro-processor system for radio remote control - DBX enclosure (12V system)	10.0.862	19.977
	5105 RKP-E 24V	remote control - DBX enclosure (24V system)	10.0.864	19.977

ACCESSORIES

Description	Part #	List price : US\$
° 8 gallons (30 lt.) reservoir oil, with filter on return line (only PTO driven)	09.5.501	167
° Hook ring for travelling block	10.2.514	61
° Kit radio remote for compressor and accelerator (7 functions in the pendant)	10.5.532	1.235
° Remote control wire 30 ft. where or when radio operation is not permitted	CV.0.071	263
° Outriggers :		
One side manual out, both legs manual up/down 4.5 F-EMO M	10.4.525	1.867
One side manual out, both legs hydraulic up/down 6 F-EMO K	10.4.526	2.923
One side hydraulic out, both legs hydraulic up/down 6 F-EHO K	10.4.527	3.372

Net price for crane packaging (conform ISPM 15 + HT) :

US\$ **190**



6206....

Rating 37,000 ft. lbs. (KNm. 51)

§ - Crane structure designed according **DIN 15018** Standards - Lifting class **H2-B3**

§ - Complies with **ANSI B30.5** (1989, rev. 1992) **OSHA** 1910-180, dtd 7-1-91

Standard features :

- telescopic boom system, two fully hydraulic stage
- protected extension cylinders placed inside the boor
- hydraulic planetary winch, high speed and efficiency
- hydraulic slewing system, unlimited, continuous rotator
- sheaves made in low friction, high strength, weather-proof polyme
- 100 ft. (30 mt.) of 25/64 " (10 mm.) rope 20,800 lbs. (9,460 kg.) minimum breaking strength, non twisting type
- travelling block, swivel hook with safety latch
- full safety control system, integrating load limiting device, anti-two block and stop-end rope system on drur
- fully digital proportional controls, enable fast, precise, smooth operation. Easy upgrading from wire to radio with minimal change
- digital processor, LED display, on IP 67 water proof casing, providing self-diagnostic and quick setting
- one handheld trigger type control box for wire or radio remote, incorporating emergency shut-off and start/stop truck engine switch
- solenoid operated valves with emergency manual overrid
- painted COBRA WHITE (RAL 9003), fading resistant polyurethane ename

With radio remote :

- magnet for control box leaning
- battery recharging cable 6 ft. (2 mt.) length with plug for in-cab cigarette lighte

HYDRAULIC CRANE

6206....H	<i>COBRA model</i>	<i>Description</i>	<i>Part #</i>	<i>List price : US\$</i>
	6206 KP-H 12V	<i>including mono-function proportional micro-processor system for cable remote control - DBX enclosure (12V system)</i>	11.0.831	20.363
	6206 KP-H 24V	<i>remote control - DBX enclosure (24V system)</i>	11.0.832	20.363
	6206 KPD-H 12V	<i>including dual-function proportional micro-processor system for cable remote control - DBX enclosure (12V system)</i>	11.0.833	20.967
	6206 KPD-H 24V	<i>remote control - DBX enclosure (24V system)</i>	11.0.834	20.967
	6206 RKP-H 12V	<i>including mono-function proportional micro-processor system for radio remote control - DBX enclosure (12V system)</i>	11.0.841	21.355
	6206 RKP-H 24V	<i>remote control - DBX enclosure (24V system)</i>	11.0.842	21.355
	6206 RKPD-H 12V	<i>including dual-function proportional micro-processor system for radio remote control - DBX enclosure (12V system)</i>	11.0.843	21.987
	6206 RKPD-H 24V	<i>remote control - DBX enclosure (24V system)</i>	11.0.844	21.987

ACCESSORIES

	<i>Description</i>	<i>Part #</i>	<i>List price : US\$</i>
◦	8 gallons (30 lt.) reservoir oil, with filter on return line	09.5.501	167
◦	Hook ring for travelling block	10.2.514	61
◦	Kit radio remote for compressor and accelerator (7 functions in the pendant)	10.5.532	1.235
◦	Remote control wire 30 ft. where or when radio operation is not permitted	CV.0.071	263
◦	Outriggers :		
	One side manual out, both legs manual up/down 4.5 F-EMO M	10.4.525	1.867
	One side manual out, both legs hydraulic up/down 6 F-EMO K	10.4.526	2.923
	One side hydraulic out, both legs hydraulic up/down 6 F-EHO K	10.4.527	3.372
	One side manual out, both legs hydraulic up/down 7 F-EMO K	14.4.511	3.189
	One side hydraulic out, both legs hydraulic up/down 7 F-EHO K	14.4.515	3.775

Net price for crane packaging (conform ISPM 15 + HT) :

US\$ **190**



8805....

Rating 52,000 ft. lbs. (KNm. 72)

§ - Crane structure designed according **DIN 15018** Standards - Lifting class **H2-B3**

§ - Complies with **ANSI B30.5** (1989, rev. 1992) **OSHA** 1910-180, dtd 7-1-91

Standard features :

- telescopic boom system, two fully hydraulic stage
- protected extension cylinders placed inside the boor
- hydraulic planetary winch, high speed and efficiency
- hydraulic slewing system, unlimited, continuous rotator
- sheaves made in low friction, high strength, weather-proof polyme
- 115 ft. (35 mt.) of 7/16 " (11 mm.) rope 22,500 lbs. (10,200 kg.) minimum breaking strength, non twisting type
- travelling block, swivel hook with safety latch
- full safety control system, integrating load limiting device, anti-two block and stop-end rope system on drur
- fully digital proportional controls, enable fast, precise, smooth operation. Easy upgrading from wire to radio with minimal change
- digital processor, LED display, on IP 67 water proof casing, providing self-diagnostic and quick setting
- one handheld trigger type control box for wire or radio remote, incorporating emergency shut-off and start/stop truck engine switch
- solenoid operated valves with emergency manual overrid
- painted COBRA WHITE (RAL 9003), fading resistant polyurethane ename

With radio remote :

- magnet for control box leaning
- battery recharging cable 6 ft. (2 mt.) length with plug for in-cab cigarette lighte

HYDRAULIC CRANE

8805....H	<i>COBRA model</i>	<i>Description</i>	<i>Part #</i>	<i>List price : US\$</i>
	8805 KPD-H 12V	<i>including dual-function proportional micro-processor system for cable remote control - DBX enclosure (12V system)</i>	14.0.861	26.011
	8805 KPD-H 24V	<i>remote control - DBX enclosure (24V system)</i>	14.0.862	26.011
	8805 RKPD-H 12V	<i>including dual-function proportional micro-processor system for radio remote control - DBX enclosure (12V system)</i>	14.0.871	27.987
	8805 RKPD-H 24V	<i>remote control - DBX enclosure (24V system)</i>	14.0.872	27.987

ACCESSORIES

<i>Description</i>	<i>Part #</i>	<i>List price : US\$</i>
◦ 13 gallons (50 lt.) reservoir oil, with filter on return line	14.5.516	265
◦ Hook ring for travelling block	14.2.516	73
◦ Kit radio remote for compressor and accelerator (7 functions in the pendant)	10.5.532	1.235
◦ Remote control wire 30 ft. where or when radio operation is not permitted	CV.0.071	263
◦ Outriggers :		
<i>One side manual out, both legs hydraulic up/down</i> <i>7 F-EMO K</i>	14.4.511	3.189
<i>One side hydraulic out, both legs hydraulic up/down</i> <i>7 F-EHO K</i>	14.4.515	3.775

Net price for crane packaging (conform ISPM 15 + HT) : **US\$ 190**



9506....

Rating 56,000 ft. lbs. (KNm. 78)

§ - Crane structure designed according **DIN 15018** Standards - Lifting class **H2-B3**

§ - Complies with **ANSI B30.5** (1989, rev. 1992) **OSHA** 1910-180, dtd 7-1-91

Standard features :

- ° telescopic boom system, two fully hydraulic stages to 22' (6,7 mt.), or three hydraulic extensions to 27' 3" (8,3 mt.)
- ° hydraulic planetary winch, high speed and efficiency
- ° hydraulic slewing system, unlimited, continuous rotation
- ° sheaves made in low friction, high strength, weather-proof polymers
- ° 115 ft. (35 mt.) of 7/16 " (11 mm.) rope 22,500 lbs. (10,200 kg.) minimum breaking strength, non twisting type
- ° travelling block, swivel hook with safety latch
- ° full safety control system, integrating load limiting device, anti-two block and stop-end rope system on drum
- ° fully digital proportional controls, enable fast, precise, smooth operation. Easy upgrading from wire to radio with minimal change
- ° digital processor, LED display, on IP 67 water proof casing, providing self-diagnostic and quick setting;
- ° one handheld trigger type control box for wire or radio remote, incorporating emergency shut-off and start/stop truck engine switch
- ° solenoid operated valves with emergency manual override
- ° painted COBRA WHITE (RAL 9003), fading resistant polyurethane enamel

With radio remote :

- ° magnet for control box leaning
- ° battery recharging cable 6 ft. (2 mt.) length with plug for in-cab cigarette lighter

HYDRAULIC CRANE

9506....H	<i>COBRA model</i>	<i>Description</i>	<i>Part #</i>	<i>List price : US\$</i>
	9506 2 KPD-H 12V		(12V system) 14.0.881	26.145
	9506 2 KPD-H 24V	including dual-function proportional micro-processor system for cable	(24V system) 14.0.882	26.145
	9506 3 KPD-H 12V	remote control - DBX enclosure	(12V system) 14.0.883	30.181
	9506 3 KPD-H 24V		(24V system) 14.0.884	30.181
	9506 2 RKPD-H 12V		(12V system) 14.0.891	28.123
	9506 2 RKPD-H 24V	including dual-function proportional micro-processor system for radio	(24V system) 14.0.892	28.123
	9506 3 RKPD-H 12V	remote control - DBX enclosure	(12V system) 14.0.893	32.159
	9506 3 RKPD-H 24V		(24V system) 14.0.894	32.159

ACCESSORIES

<i>Description</i>	<i>Part #</i>	<i>List price : US\$</i>
° 13 gallons (50 lt.) reservoir oil, with filter on return line	14.5.516	265
° Hook ring for travelling block	14.2.516	73
° Kit radio remote for compressor and accelerator (7 functions in the pendant)	10.5.532	1.235
° Remote control wire 30 ft. where or when radio operation is not permitted	CV.0.071	263
° Outriggers :		
One side manual out, both legs hydraulic up/down	7 F-EMO K	14.4.511
One side hydraulic out, both legs hydraulic up/down	7 F-EHO K	14.4.515

Net price for crane packaging (conform ISPM 15 + HT) :

US\$ **190**

§ - Crane structure designed according **DIN 15018** Standards - Lifting class **H2-B3**

§ - Complies with **ANSI B30.5** (1989, rev. 1992) **OSHA** 1910-180, dtd 7-1-91

Standard features :

- telescopic boom system, two fully hydraulic stages to 22' (6,7 mt.), or three hydraulic extensions to 27' 6" (8,4 mt.)
- hydraulic planetary winch, high speed and efficiency
- hydraulic slewing system, unlimited, continuous rotation
- sheaves made in low friction, high strength, weather-proof polymers
- 115 ft. (35 mt.) of 15/32 " (12 mm.) rope 33,000 lbs. (15,000 kg.) minimum breaking strength, non twisting type
- travelling block, swivel hook with safety latch
- full safety control system, integrating load limiting device, anti-two block and stop-end rope system on drum
- fully digital proportional controls, enable fast, precise, smooth operation. Easy upgrading from wire to radio with minimal change
- digital processor, LED display, on IP 67 water proof casing, providing self-diagnostic and quick setting
- one handheld trigger type control box for wire or radio remote, incorporating emergency shut-off and start/stop truck engine switch
- solenoid operated valves with emergency manual override
- painted COBRA WHITE (RAL 9003), fading resistant polyurethane enamel

With radio remote :

- magnet for control box leaning
- battery recharging cable 6 ft. (2 mt.) length with plug for in-cab cigarette lighter

HYDRAULIC CRANE

12006....H	<i>COBRA model</i>	<i>Description</i>	<i>Part #</i>	<i>List price : US\$</i>
	12006 2 KPD-H 12V	<i>including dual-function proportional micro-processor system for cable remote control - DBX enclosure</i>	<i>(12V system)</i> 19.0.835	28.391
	12006 3 KPD-H 12V	<i>remote control - DBX enclosure</i>	<i>(12V system)</i> 19.0.837	32.763
	12006 2 RKPD-H 12V	<i>including dual-function proportional micro-processor system for radio remote control - DBX enclosure</i>	<i>(12V system)</i> 19.0.845	30.367
	12006 3 RKPD-H 12V	<i>remote control - DBX enclosure</i>	<i>(12V system)</i> 19.0.847	34.739

ACCESSORIES

<i>Description</i>	<i>Part #</i>	<i>List price : US\$</i>
◦ 13 gallons (50 lt.) reservoir oil, with filter on return line	14.5.516	265
◦ Hook ring for travelling block	14.2.516	73
◦ Kit radio remote for compressor and accelerator (7 functions in the pendant)	10.5.532	1.235
◦ Remote control wire 30 ft. where or when radio operation is not permitted	CV.0.071	263
◦ Outriggers :		
One side manual out, both legs hydraulic up/down	7 F-EMO K	14.4.511
One side hydraulic out, both legs hydraulic up/down	7 F-EHO K	14.4.515

Net price for crane packaging (conform ISPM 15 + HT) : US\$ **190**